

Designation:

**Double swivel single-lever mixer tap 1/2“  
Stainless steel**

Article number:

**201-101/200+200-380**





**201-101/300+300-380**

Description:

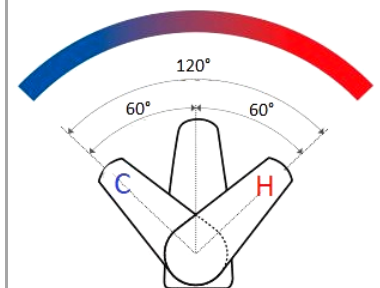
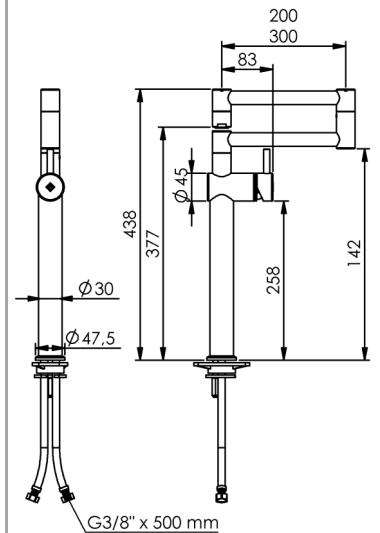
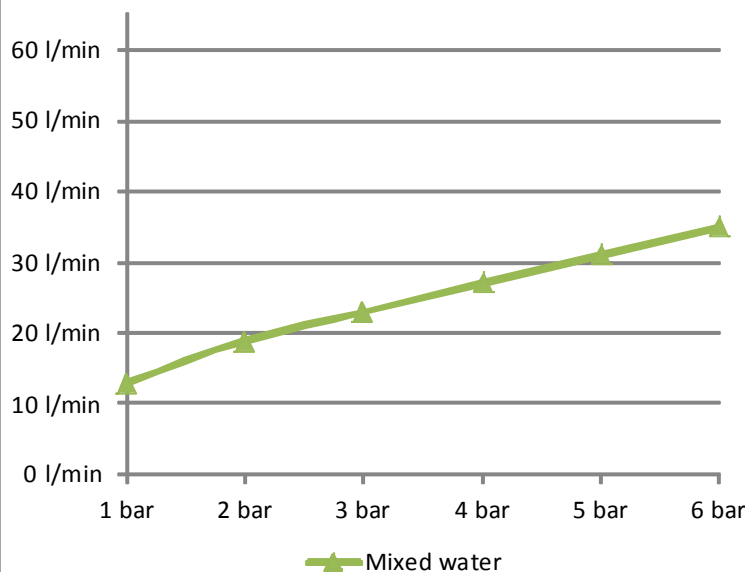
- Designed for high pressure only, operating pressure 1-6 bar
- Heat insulating handle, lateral
- Double swivel valve with JetSafe (drip stop)
- Projection per arm A = 200 mm / 300 mm
- Height under spout H = 380 mm
- Temperature and flow control with modern eco ceramic cartridge, with high flow rate
- Connection via 2 x copper pipes with connection nozzle 1/2“
- Easy to install fastening system with fastening nut and connecting piece with G 1 1/4“ x 50 mm
- Material **stainless steel**
- Hot water resistant up to 80°C
- Worktop bore hole Ø43 mm

Flow rate:



<p>Proper use:</p>	<p>The pre rinse spray unit is used in commercial kitchens. The fitting must only be operated by trained specialist staff with a minimum age of 14 years.</p> <p>Assembly oder disassembly may only be carried out by certified specialist tradesmen.</p>	
<p>Improper use:</p>	<p>The fitting is <b>not</b> suitable for connection to low pressure hot water boilers.</p>	
<p>Hazard warning:</p>	<p>In case of disassembly or repair the angle valves should be shut off.</p>	
<p>Care instructions:</p>	<p><b>Do not</b> use cleaning agents with a high chlorine or acid content. Refrain from using high-pressure cleaning devices, as defined in work sheet VdF 018, for instance.</p> <p><b>No types</b> of scouring agents are to be used for cleaning purposes as they scratch the surface.</p>	
<p>Admissions:</p>	<p><b>All seals meet the requirements for plastics in contact with water and the requirements of DVGW work sheet W 270.</b></p>	
<p>Manufacturer:</p>	<p><b>Gebr. Echtermann GmbH &amp; Co.KG</b>                  P.O. Box 1456                  D 58584 Iserlohn</p> <p>Tel: +49 (0) 2371 / 9582-0                  Fax: +49 (0) 2371 / 52787                  Email: <a href="mailto:contact@echtermann.de">contact@echtermann.de</a></p>	